



V CLASS
WATER COOLED CHILLERS
Oil-Free Centrifugal Chiller

SMART



CONTENTS

04 INTRODUCTION

- 04 Proprietary Notice
- 04 Document Purpose
- 05 Smardt Chiller Group

07 V CLASS OVERVIEW

08 FEATURES & BENEFITS

- 08 Oil-Free Compressor Technology
- 08 Largest Capacity Range
- 08 High Efficiency
- 08 Flash Economisers
- 08 Compact
- 08 Control System
- 09 IntraFlow™ Technology
- 09 Independent Power Modules
- 09 Environmentally Responsible
- 09 Serviceability
- 09 Reliability & Redundancy

10 CAPACITY RANGE

11 AVAILABLE OPTIONS

- 11 Condenser Protection
- 11 Alternative Insulation
- 11 Water Connections
- 11 Remote Connectivity
- 11 Rapid Restart
- 11 High-Level Communications
- 11 Power Monitoring

12 APPLICATION CONSIDERATIONS

- 12 Chilled Water Requirements
- 12 Evaporator Water Circuits
- 12 Chilled Water Temperature Limits
- 12 Flow Safety Interlocks



PROPRIETARY NOTICE

This publication contains information proprietary and confidential to Smardt Chiller Group Inc. and its subsidiary companies ("Smardt"). Any reproduction, disclosure or unauthorized use of this publication is expressly prohibited without written permission from Smardt.

Smardt reserves the right to make changes to the product or component design as and when warranted and without notice, in line with user needs or evolution in engineering and manufacturing technologies.

Smardt has exercised its best efforts to ensure that the information contained in this manual is correct at time of printing. However, no warranty, reliability or accuracy is given with respect to the information contained herein, and Smardt is not and shall not be responsible for any error or omission, or liable for the correctness or suitability of the information given.

All brand names and product names used in this manual are trademarks, registered trademarks, or trade names of their respective holders.

DOCUMENT PURPOSE

This catalogue provides a general overview of Smardt's V Class water cooled chiller range, including the key features and options available. It is intended as a general guide for the appropriate selection and application of V Class water cooled chiller units.

For specific application information, contact your nearest Smardt sales representative.

The information provided is general in nature, and is subject to change as part of Smardt's commitment to continuous product improvement.

Revised manuals are not distributed unless recipients specifically subscribe to the revised documents. Please contact Smardt to ensure you have latest version.



SMARTD CHILLER GROUP

Smartd is “Global Number One” in oil-free centrifugal chillers, with production facilities in Stuttgart, Germany; Melbourne, Australia; Plattsburgh, New York; Guangzhou, Guangdong and Montreal, Canada. Smartd service networks extend across the globe; they monitor and support the world’s largest installed base of oil-free high-efficiency chillers (well over 5000 by the end of 2015). Smartd started a global reputation with the first oil-free centrifugal prototype built in 2002 to help refine Turbocor’s compressor technology before its launch in 2003. Smartd’s lowest lifecycle costs make such a major contribution to an owner’s long term values that they make chiller first cost differences largely irrelevant.

Since 2002, Smartd has built, tested and continually refined the world’s widest oil-free chiller range. Water cooled high-efficiency chillers from 200 kW up to over 8 MW, air cooled chillers from 200 kW to 2 MW, adiabatic chillers to over 1 MW, modular, split, condenserless and other variations match a wide range of specific applications. Free cooling (standard coil or thermosyphon)

and heat recovery applications are increasingly specified. The Smartd range covers a wide range of non-standard conditions, e.g. in fluids (glycols, brines and others). Increasing focus on low-GWP refrigerants is reflected in installed Smartd chillers in Switzerland and other countries. Smartd innovations have resulted in a number of patents and patent applications.

Unlike all other global chiller brands, Smartd’s global innovation programs are wholly dedicated to Smartd customers and the value they earn from their Smartd chillers. In compressors, Smartd has been working closely with Turbocor since 2002 (Smartd founder Roger Richmond-Smith is also a founder of Turbocor), and the two companies continue to share detailed test programs. In heat exchangers, Smartd’s research work on metallurgy, corrosion resistance, flow and heat transfer management has led to several patents and patent applications. In systems integration and controls, Smartd software innovations mean major advances in operating efficiencies, effective redundancy and responsiveness. In service support, training, monitoring and continuous

commissioning, Smartd programs continue to develop. Seamless optimisation of whole variable speed chiller plants using Smartd chillers shows further major gains in energy efficiency.

SMARTD MARKETS ACHIEVING MAJOR ENERGY REDUCTIONS

- DATA CENTRES
(ESPECIALLY BANKING & OTHER FINANCIAL INSTITUTIONS)
- HOSPITALS & HEALTHCARE
- HOTELS
- PROCESS COOLING
- EDUCATIONAL & INSTITUTIONAL CAMPUSES
- CONCERT HALLS & OPERA HOUSES
- MARINE
- LARGE COMMERCIAL BUILDINGS
- DISTRICT COOLING SYSTEMS

Smardt's range of V Class water cooled chillers delivers new levels of efficiency and reliability within a compact, larger capacity chiller. Utilising the latest oil-free compression technology, with an integrated economiser, the V Class delivers class leading efficiency over an extended performance envelope.

Smardt, as the globally trusted leader in oil-free centrifugal chillers, has extended its proven platform of high efficiency water cooled chillers into the large chiller market with the V Class range.

As with all Smardt chillers, the V Class delivers the highest level of reliability, outstanding efficiency, and the lowest total cost of ownership by utilising the latest in oil-free magnetic bearing compression technology.

Setting the V Class apart though, is the application of Danfoss Turbocor VTT compressors, producing the highest capacities in oil-free chillers within a compact footprint.

Accurate and responsive load control is now possible across an unparalleled range of capacities, even low loads, thanks to Smardt's innovative load control, high performance heat exchangers and dedicated economisers.

Our class leading performance and quality design, with a focus on simplicity of operation and maintenance, ensures the best results for total equipment lifecycle operation and reliability.



HIGHLIGHTS

- Largest capacity range in oil-free water cooled chillers.
- Typically smaller footprint when compared with chillers of a comparable capacity.
- Patented IntraFlow™ load control eliminates mechanical throttling, and refrigerant leaks from external actuators.
- Responsive chilled water control in all conditions.
- Inbuilt redundancy with multiple compressors.
- Class leading part load efficiencies, achieving the highest IPLV in total capacity range.
- Designed for ease of maintenance and serviceability, featuring field-serviceable compressors.
- Dual-turbine compression technology, coupled with an economiser, delivering class leading performance
- Australian manufactured, acceptance tested and pre-commissioned prior to delivery ensuring trouble-free commissioning and startup on every project.

The V Class extends the best of Smardt's oil-free centrifugal water cooled chillers into new territory.

OIL-FREE COMPRESSOR TECHNOLOGY

At the core of all Smardt chillers is an oil-free Danfoss Turbocor compressor, featuring magnetic bearing technology. With no oil to compromise heat exchanger performance, and no friction losses associated with conventional compressor bearings, Smardt chillers are able to achieve exceptional full- and part-load efficiencies.

This technology eliminates up to 99% of compressor induced vibrations, and dramatically reduces the sound levels emitted by the chiller.

LARGEST CAPACITY RANGE

Smardt have reset the boundaries - now offering the largest capacity range of water cooled oil-free chillers in the world, with the V Class able to achieve capacities exceeding 8MW of cooling, while continuing to exceed MEPS efficiency requirements.

HIGH EFFICIENCY

All Smardt chillers use a premium flooded shell and tube heat exchanger which has superior efficiency and reliability to plate and frame or DX heat exchangers.

FLASH ECONOMISERS

Economisers are a proven key to boosting chiller efficiency and capacity, but can only be used with two-stage compressors - as found on all Smardt chillers.

Every V Class chiller now features high performance flash tank economisers, as standard.

COMPACT

V Class chillers offer a small footprint, when compared with oil-free chillers of a comparable capacity. Through the use of larger capacity compressors, in place of multiple smaller compressors, chilled water plants can now experience the efficiency of oil free without sacrificing space.

CONTROL SYSTEM

Proven across years of industry experience in oil free chiller operation, Smardt's advanced chiller controller is designed to optimize the performance & capabilities of the V Class chiller range.

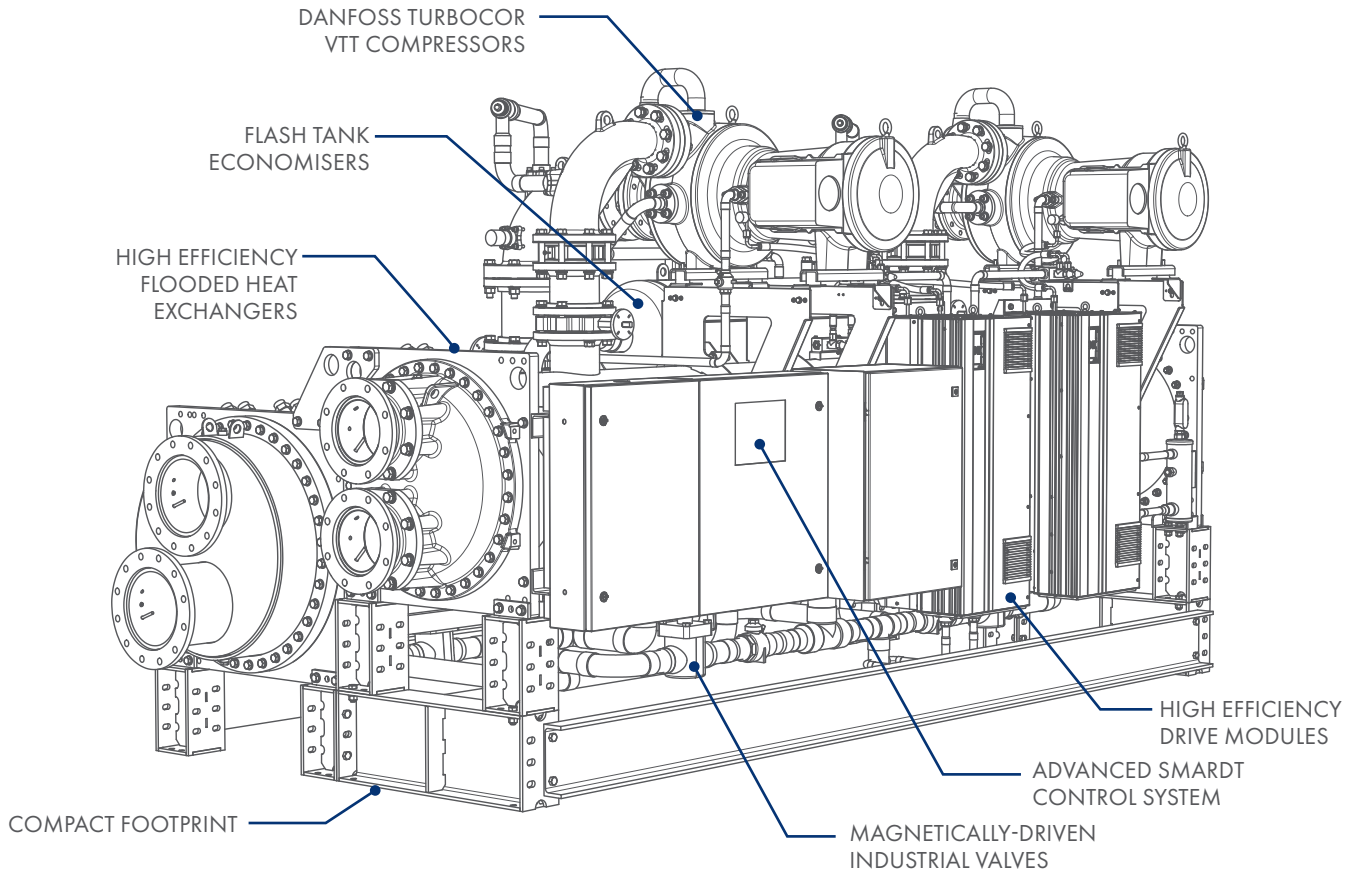

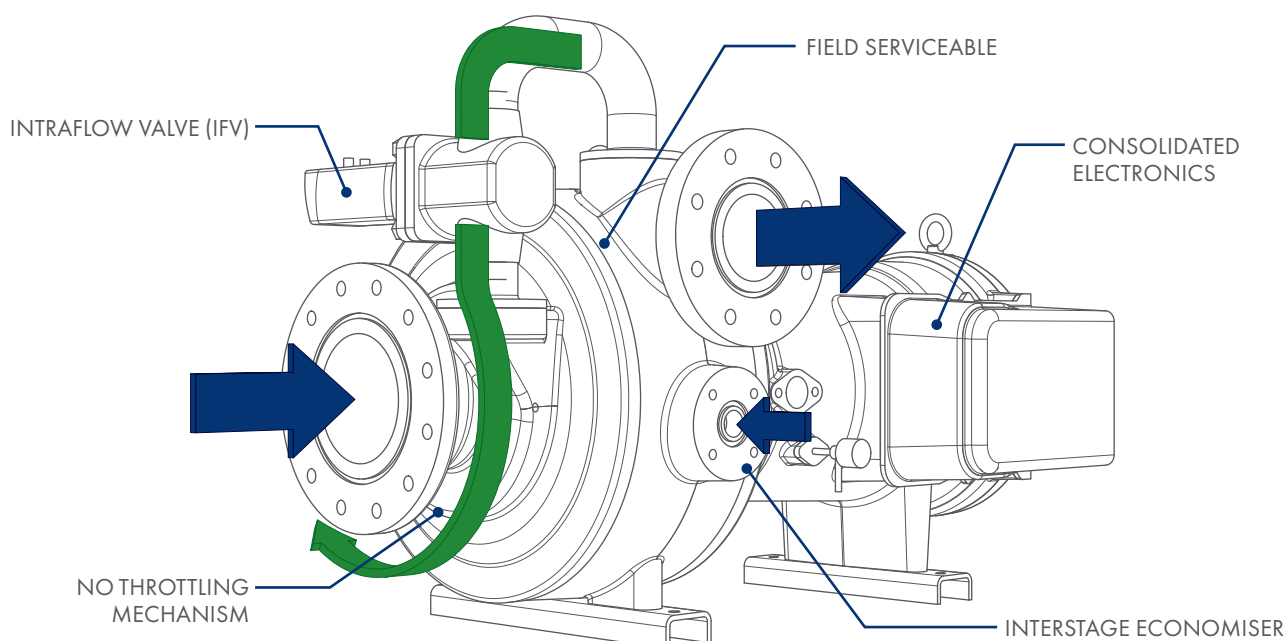

INTRAFLOW™ TECHNOLOGY

Danfoss Turbocor's patented Intraflow™ technology provides enhanced capacity turndown on all V Class chillers, effectively eliminating surge constraints, and the energy wasted through the use of hot gas bypass.

Intraflow™ technology meters high velocity discharge gas into the impeller housing to manipulate its aerodynamic conditions. This removes the need for complex inlet guide vanes and mechanical/variable geometry diffusers to throttle the incoming vapour and eliminates the leak potential of external actuators.

The result is an extended stable operating envelope, especially at lower capacities, where compressor speed and the IntraFlow™ are balanced to meet any cooling demand in the most efficient way.

INDEPENDENT POWER MODULES

High efficiency drive modules are now independent of the compressor, simplifying the compressors' on-board electronics. These drives are based on Danfoss' proven and reliable platform of HVAC variable frequency drives, while being the first to feature the combination of air and refrigerant cooling - providing enhanced redundancy.

ENVIRONMENTALLY RESPONSIBLE

All V Class chillers use R134a refrigerant as standard, which has no ozone-depletion potential, is non-toxic, non-harmful and has no phase-out schedule per the Montreal protocol.

SERVICEABILITY

All Smardt chillers include refrigerant isolation valves on both sides of all serviceable components as standard. This facilitates servicing without the need to pump down the entire unit, and in most cases can be undertaken while the chiller remains operational.

Field-serviceable compressors are a unique feature of the V Class range, effectively eliminating the time, cost and difficulty of removing large compressors.

The V Class range utilises hermetically sealed industrial valves for its expansion and IntraFlow™ valves, which feature magnetic actuators that can be removed without compromising the refrigerant circuit.

RELIABILITY & REDUNDANCY

With the experience of more than 5000 oil-free centrifugal chillers now installed worldwide, Smardt chillers offer outstanding reliability - unsurprising when an estimated 80% of all chiller field problems relate to failures in the compressor oil-return.

On multiple-compressor models, mechanical and electrical isolation provides significant redundancy and failsafes. In the event of a compressor outage, Smardt's controller will automatically adjust its logic to continue serving the chilled water load with the remaining available compressors. Should a compressor require servicing, it can be quickly & easily isolated, even removed, without stopping the chiller.

CAPACITY RANGE



The V Class range has been designed to meet a wide variety of applications, with full load capacities ranging from 1000kWR up to 8150kWR.

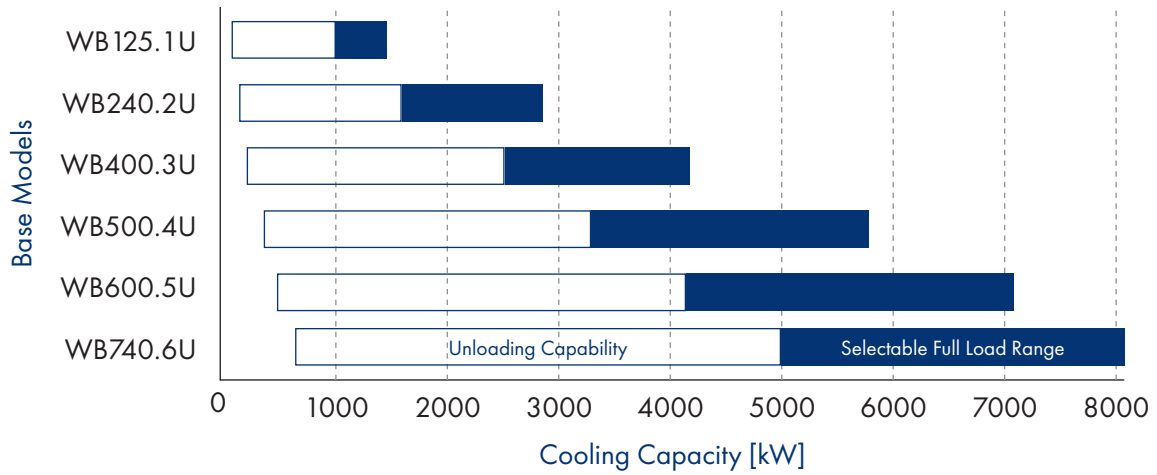

Note: Available cooling capacity will vary with operating conditions and chiller configuration. Capacities shown are based on standard AHRI conditions.

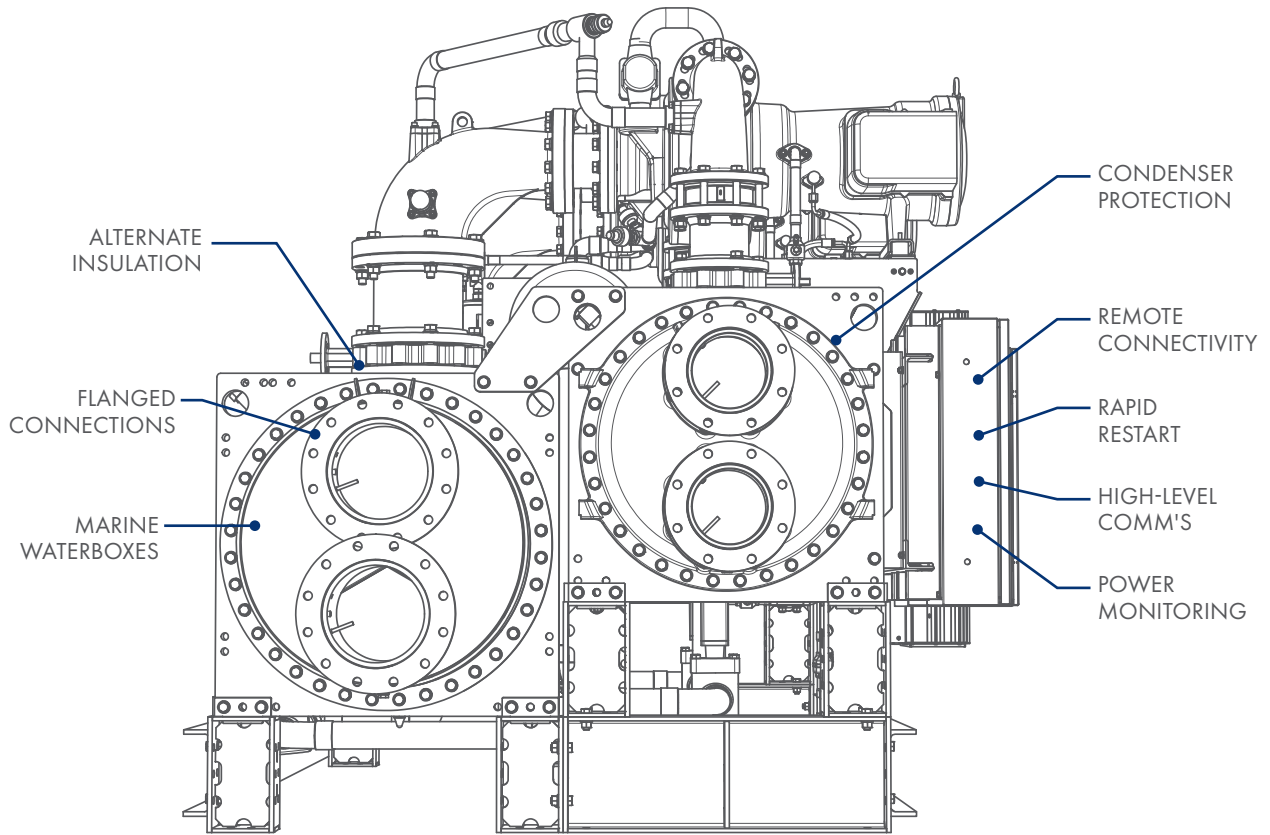

CONDENSER PROTECTION

Stainless steel tubesheets and waterboxes are available to extend the service life of your chiller, even in severe environments.

For extreme environments, Copper/Nickel and Titanium heat exchanger tube materials can also be specified. Anodic and cathodic protection options are also available.

ALTERNATIVE INSULATION

All evaporators are fitted with 19mm [3/4"] closed-cell rubber, wrapped in 3mm thick UV stabilised insertion rubber, as standard. 38mm rubber, aluminium cladding, 50mm polystyrene and 50mm polyurethane options are also available.

WATER CONNECTIONS

Grooved connections are supplied as standard on all models. Flanged options, including AS Table 'E' and ANSI #150, are available on request.

Marine waterboxes are also available on all V Class units.

REMOTE CONNECTIVITY

Access data trending, or real time feedback on chiller status and performance remotely.

RAPID RESTART

Designed for critical installations, Rapid Restart allows the chiller to resume operation in as little as 20 seconds following power supply restoration.

HIGH-LEVEL COMMUNICATIONS

BACnet, BACnet IP, MSTP and REMOTE communication options are available as alternatives to MODBUS, which is included as standard.

POWER MONITORING

An integrated monitoring system, providing absolute power usage & quality in real time over HLI.

APPLICATION CONSIDERATIONS

CHILLED WATER REQUIREMENTS

All external pipework must be self-supporting, and aligned to prevent strain and distortion on the chiller's headers and couplings.

EVAPORATOR WATER CIRCUITS

The chiller performance and efficiency can be adversely affected by contaminants in the water circuit. As such, strainers should be located on the inlet side of the evaporator.

The water circuit should be arranged so that the pumps discharge through the evaporator, with the return water to the chiller connected to the lower connection of the evaporator.

CHILLED WATER TEMPERATURE LIMITS

V Class water cooled chillers are optimised for chilled water temperatures between 4°C and 22°C. For applications outside this range, please consult your local sales representative.

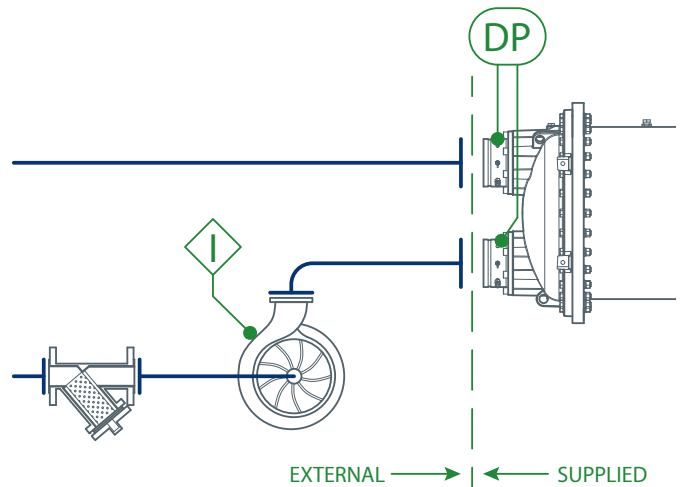

FLOW SAFETY INTERLOCKS

Differential pressure (DP) transmitters are fitted as standard on all Smartd chillers, which enables the chiller to shutdown in the event of low or high flow through the evaporator.

An additional field-supplied chilled water pump interlock, or a VSD interlock signal are required on all installations.

If the chiller is intended for an application using variable chilled water flow, please confirm the appropriate cut off point with Smartd.

GLOBAL PRESENCE



AMERICAS

CANADA

1800 Trans Canada Highway
Dorval Quebec H9P1H7
T +1 514 426 8989
F +1 514 426 5757
E sales@swardt.com

USA

22 Colorado Street Bldg2815
Plattsburgh NY 12903
T +1 518 324 5741
F +1 518 324 5718
E sales@swardt.com

BRAZIL

Swardt and Transcalor
Av. Eldorado, 187 – Jardim Ruyce – Diadema
SP – Brasil – CEP: 09961-470
T +55 11 4351-4089 / 4351-3803
E contato@transcalor.com.br

EUROPE, MIDDLE EAST, AFRICA

GERMANY

Bahnhofstraße 74
D73240 Wendlingen
T +49 7024 79429 0
F +49 7024 79429 22
E info.eu@swardt.com

ASIA PACIFIC

CHINA

Mei Xing Industrial Park
No. 30 Dong Zhong Road ETDD
Guangzhou
T + 86 20 8205 7161
F + 86 20 8200 1302
E info@swardtchina.com

SINGAPORE

108 Pasir Panjang Road #04-10
Golden Agri Plaza S118535
T +65 6273 1120
F +65 6273 1129
E sales.as@swardt.com

AUSTRALIA

144 Colchester Road
Bayswater North VIC 3153
T +61 3 9761 7905
F +61 3 9761 6707
E sales.au@swardt.com